



PROFILO PR U50 RULLI SERIE 129/GL

È il sistema semplice e ideale per realizzare trasportatori a più corsie di rulli nella movimentazione di colli medio-pesanti, tipo pallet o contenitori.

Si ottiene con la combinazione dei rulli serie 129 e GL 50Z con il profilo PR U50.

I rulli 129 sono costituiti da un mantello compatto e robusto in Poliammide di colore nero e testate in Polipropilene di colore giallo RAL 1023, o del colore alternativo a richiesta, con cuscinetti radiali rigidi 6002.

I rulli GL sono completamente zincati con cuscinetti a pieno riempimento di sfere. A parte vengono forniti i perni in acciaio zincato completi di borchie (starlock) per il fissaggio nel profilo.

Il profilo a U è ottenuto con lamiera zincata a caldo sendzimir e presenta una foratura multipla a passo 26 mm. anche sulla base.

È particolarmente robusto, come si può rilevare dal diagramma sotto riportato.

La fornitura prevede i componenti sfusi, secondo i codici di ordinazione. Il profilo ha lunghezza 6075 mm circa e deve essere intestato per ottenere il primo foro a 13 mm. dall'estremità.

TRACK PROFILE PR U50 ROLLERS SERIES 129/GL

It's the simple and ideal system to carry out multi roller tracks conveyors for medium-heavy weight pallets or containers handling. It is obtained by combining rollers series 129 and GL 50Z with the profile PR U50.

The 129 rollers are made of rugged and compact Polyamide black casing and yellow RAL 1023, or in the alternative colour on request, Polypropilene end-caps with precision ball bearings 6002.

The GL are zinc-plated rollers with bearings without cage.

Separately, zinc-plated steel pins, complete with bosses (starlock), are supplied for fixing into the profile.

U profile is obtained with Z hot zinc-plated iron sheet (sendzimir) and presents a multiple drilling at 26 mm. pitch also on the base. It is particularly strong, as it results from the diagram herebelow. The supply foresees loose components following the ordering codes. The profile has a length of 6075 mm and must be faced to obtain the first hole, 13 mm. distant from the end.

RSV/4

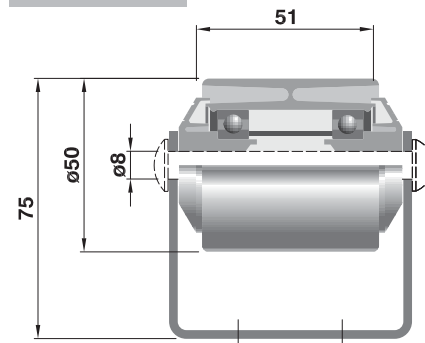

RSV/5

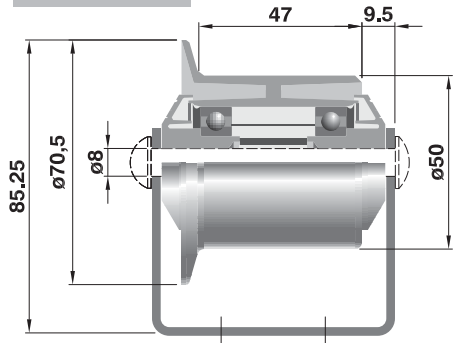

GL/8

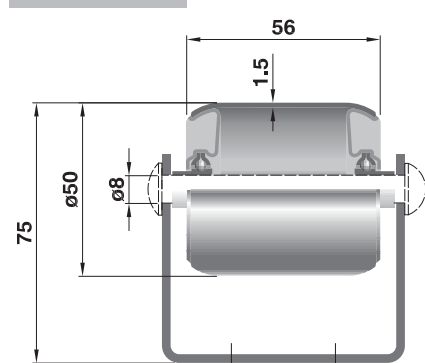

GL/68

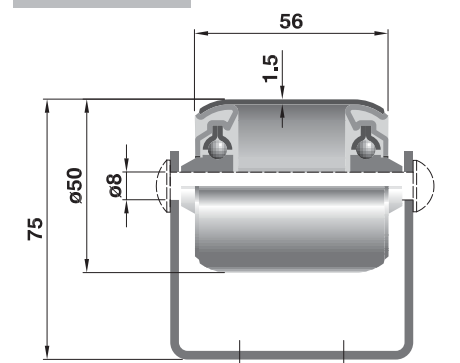

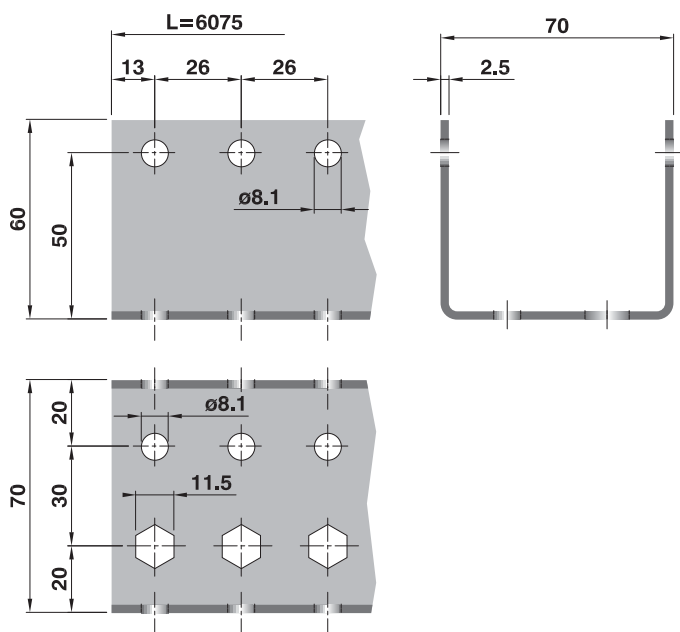
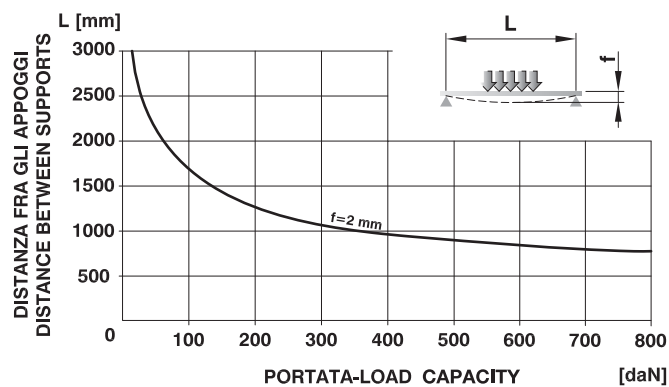
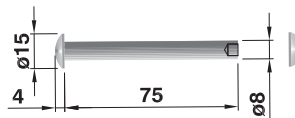
PR U50

RSV/A1

Tipo Type	Peso Weight daN	Portata Load Capacity daN	Note Notes
RSV/4 129	0,116	40	rulli in poliammide senza bordino - polyamide rollers without flange
RSV/5 129	0,120	40	rulli in poliammide con bordino - polyamide rollers with flange
GL/8 50Z 64	0,110	50	rulli zincati - zinc plated rollers
GL/68 50Z 64	0,125	120	rulli zincati - zinc plated rollers
RSV/A1 129	0,035	-	perni e starlock - pins and starlock
PR U50 6075	22,420	-	profilo in lamiera zincata - zinc-plated iron sheet profile

Il perno in acciaio zincato completo di borchia-fissaggio (starlock) deve essere ordinato separatamente.
 The zinc-plated steel pin complete with starlock must be ordered separately.