

3 Troughing sets



3.5 - Cantilevered sets

The development of this troughing set is the result of long practical experience in the field.

The two rollers that comprise the set are assembled onto a single shaft of 15 mm diameter and their external end caps hermetically sealed. Together with the central support the unitary assembly is extremely strong.

Cantilevered sets are available with rollers from series RTL and MPS and their use is applicable to light or medium load capacity belt conveyors with small material piece size.

The support positions the two rollers in a manner that minimises the gap between them, without affecting their free rotation.

In this manner the belt is perfectly supported and no damage results even to a flexible belt due to the proximity of the two support rollers.

The cantilevered sets may be located by their support fixing with screws or onto an appropriate base plate part number SPT1316.

The support brackets of the set have been designed with longitudinal "fixing" slots to allow for perfect belt alignment.



**cantilever
sets
GRS**



type	roller		belt					weight
	series	Ø mm	width mm	B mm	H	S	e	Kg
GRS 1	MPS	60N	300	195	149	417	48	3.0
			400	245	167	511	48	3.6
			450	275	177	568	53	3.9
			500	305	188	624	58	4.2
			600	355	205	714	58	4.8
GRS 1	MPS	76N	300	195	157	423	46	3.5
			400	245	174	517	46	4.1
			450	275	185	573	51	4.5
			500	305	195	629	56	4.9
			600	355	213	723	56	5.6

The table indicates the dimensions and the type of cantilever sets for various belt widths.
The maximum load capacity is calculated based on a life of 10,000 hours in relation to a belt speed of 1-2 m/s.

max load capacity with rollers series MPS 95 Kg



Example of ordering
GRS 4, 76N, 500
Base plate SPT 1316

3 Troughing sets

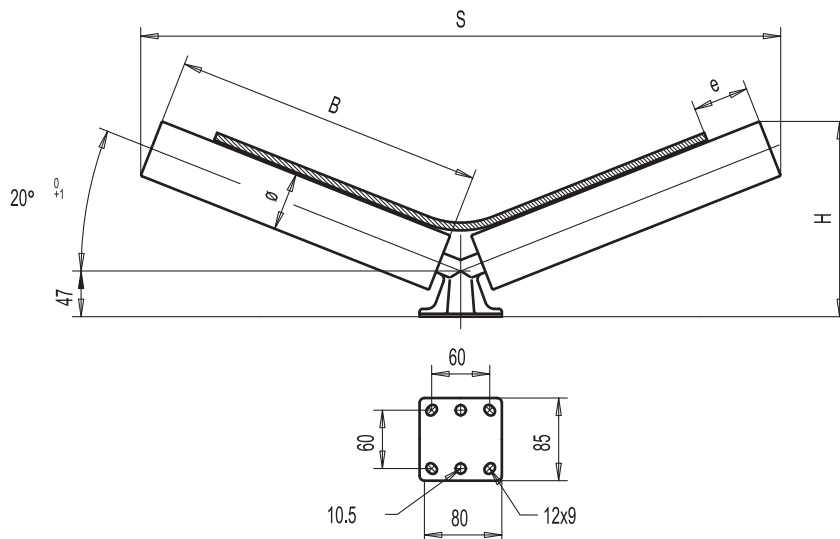

type	roller		belt					weight Kg
	series	Ø mm	width mm	B mm	H	S	e	
GRS 21	RTL	60N	300	195	149	417	48	2.2
			400	245	167	511	48	2.7
			450	275	177	568	53	2.9
			500	305	188	624	58	3.2
			600	355	205	714	58	3.6
GRS 22	RTL	76N	300	195	157	423	46	2.6
			400	245	174	517	46	3.1
			450	275	185	573	51	3.5
			500	305	195	629	56	3.7
			600	355	213	723	56	4.2

The table indicates the dimensions and the type of cantilever sets for various belt widths. The maximum load capacity is calculated based on a life of 10,000 hours in relation to a belt speed of 1-2 m/s.

max load capacity with rollers series RTL 75 Kg

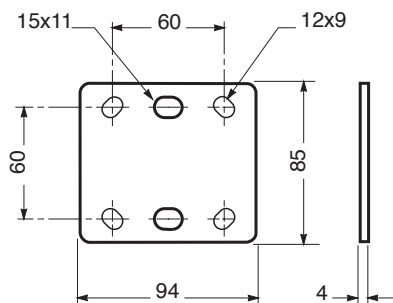

Base plate type SPT 1316
To be welded to structure to allow bolting the cantilever set to it.

Example of ordering
GRS 23, 76N, 450
Base plate SPT 1316