

**RULMECA SCRAPERS WITH  
BLADES IN POLYURETHANE**

FOR BULK HANDLING

**Moving ahead.**



- Type PU-83      Simple Pre-scraper with single polyurethane blade**  
 Position: Tangential for pulleys Ø 220-1000 mm  
 For BW 400-2000, max speed 3.5 m/s, also reversible  
 For easy to medium cleaning  
 Typically a first scraper for an end user  
 Also used by many OEM as a standard scraper  
 Easy to replace the scraper blade without tools  
 The scraper must not be fitted to chevron belts or belts with mechanical joints  
 For materials: Sand, Gravel, Stone, Saw dust, garbage, soil
- Type PU-89      Heavy Pre-scraper single strong and thick polyurethane blade**  
 Position: Tangential for big pulleys Ø 400-1000 mm  
 For BW 650-1400, max speed 3.5 m/s, also reversible  
 For heavy cleaning  
 Easy to replace the scraper blade without tools  
 The scraper must not be fitted to chevron belts or belts with mechanical joints  
 For materials: Gravel, limestone, crushed stone, iron ore, cement
- Type PU-91      Pre-scraper with segment polyurethane blades**  
 Position: Tangential for pulleys Ø 200-630 mm  
 For BW 400-2000, max speed 3.5 m/s, also reversible  
 Medium to heavy cleaning  
 Accurate cleaning due to flexible multi sectored blades  
 Easy to service and maintain  
 The scraper must not be fitted to chevron belts or belts with mechanical joints  
 For materials: Sand, Gravel, crushed stone, wet and sticky material
- Type PU-92      Secondary scraper**  
 Single strong and thick polyurethane blade and pre-tensioning device  
 Position: under the return belt 30-100 mm away from the head pulley  
 For BW 400-2000, max speed 3.5 m/s, single direction belts  
 For medium industry with stringent cleaning requirements  
 Also in combination with a pre-scraper for a max cleaning effect  
 Easy to service and maintain  
 Can be fitted with tungsten-carbide blades  
 The scraper must not be fitted to chevron belts or belts with mechanical joints  
 For materials: Gravel, limestone, crushed stone, iron ore, cement and others
- Type PU-88      Plough scraper**  
 Self aligning steel frame and 2 exchangeable PU-scraper strips.  
 Position: on the return belt before the tail pulley  
 For BW 400-1800, max speed 3.5 m/s; the plough can be modified for reversible drive  
 The purpose of the plough is to remove loose material from the return run of the belt

**NOTES      Working temperatures of PU Rulmeca scrapers:**

Max. temperature: + 50°C in wet environments  
 Max. temperature: + 85°C in dry environments  
 (ambient temperature + frictional heat)

Option for surface of steel parts:

Powder coat 60-80 um  
 Coating with thermo plastic 120-800 um  
 Stainless steel EN 1.4301 /AISI 304 / SS2333





See also "Guide table for Rulmeca PU series polyurethane scrapers selection" on page 3



**SCHIKI**

**Guide Table for Rulmecca PU Series Polyurethane Scrapers Selection**



Scraper Code	Type	Blade	Position	BW mm	Max Speed m/s	Reversible Belt	Application	Options	Shape
PU-83	Simple Pre-Scraper	PU Single	Tangential to pulley Ø220-1000	400-2000	3.5	✓	For easy to medium duty cleaning	See notes at page 1	
PU-89	Heavy PU Single	PU Single Thick	Tangential to pulley Ø400-1000	650-1400	3.5	✓	For heavy duty cleaning	See notes at page 1	
PU-91	Pre-Scraper with segment PU blades	PU Segments	Tangential to pulley Ø220-630	400-2000	3.5	✓	Medium to heavy duty cleaning. Accurate cleaning due to flexible multi sector blades	See notes at page 1	
PU-92	Secondary Scraper	PU Single Thick	Under the return belt (800-100 mm from head pulley)	400-2000	3.5	No	For medium duty with stringent cleaning requirements. Also in combination of a pre-scraper for a max cleaning effect	On request: PU sectors with tungsten-carbide blades	
PU-88	Plough Scraper	2 PU Strips at V	On the return run of the belt (near tail pulley)	400-1800	3.5	Adaptable	To remove loose material from the return upper run of the belt	See notes at page 1	



**Simple Pre-Scraper  
with single PU blade  
Type PU 83**

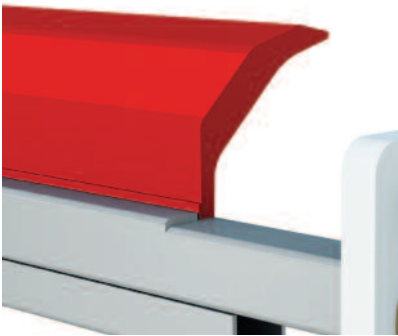
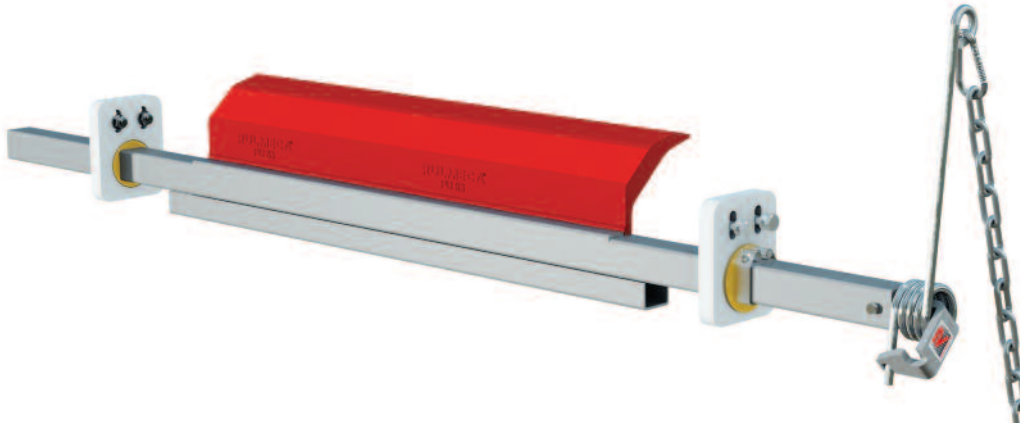

The PU 83 pre-scraper truly symbolizes our aim of making simple, effective scrapers.

**Simplicity:** the scraper strip is easy to remove from the beam (without tools) for replacement and cleaning. Simple holders guarantee easy fitting and functionality. A lever arm that is fixed to the frame using a chain produces the required scraper pressure.

Made for pulleys  $\varnothing 220-1000$  mm

B-W 400-2000mm

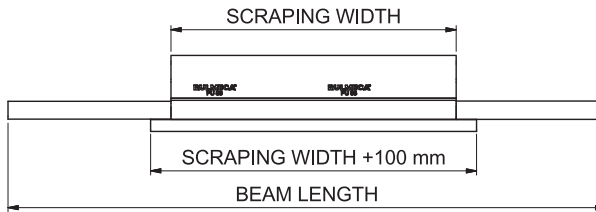
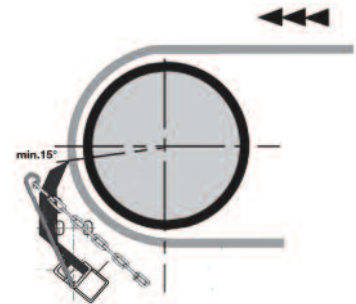

Belt Width	Scraping Width	Beam Length
400	350	1150
500	450	1250
650	550	1350
800	700	1500
1000	900	1700
1200	1050	1850
1400	1250	2050
1600	1450	2250
1800	1650	2450
2000	1850	2650

For the mounting manual of this scraper please visit our web site:  
[www.rulmecca.com](http://www.rulmecca.com) / Bulk products / accessories / scrapers



**Heavy Pre-Scraper  
with single PU blade  
Type PU 89**

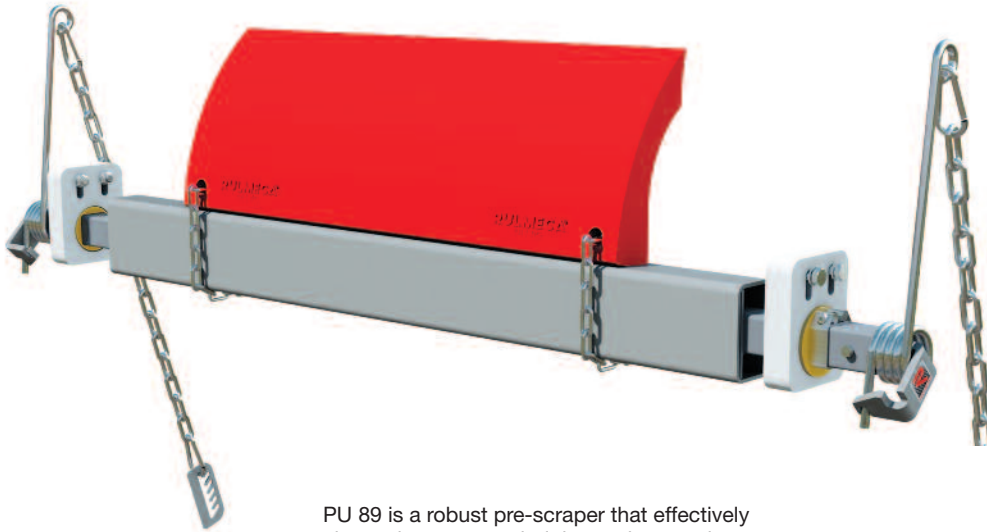

PU 89 is a robust pre-scraper that effectively cleans the conveyor belt in tough operating environments.

Made for pulleys  $\varnothing 400 - 1000$  mm.

The scraper blade is a solid polyurethane strip that adapts to the shape of the conveyor belt and pulley. Changing the blade is very easy and can be done without any tools. The scraper has been designed with a minimum of moving parts.

B-W 650-1400mm

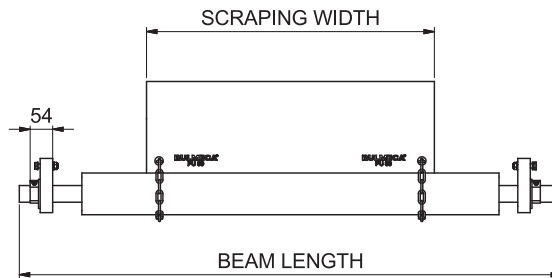
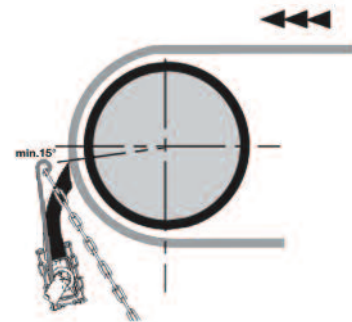

Belt Width	Scraping Width	Beam Length
650	545	850
800	695	1300
1000	895	1500
1200	1095	1700
1400	1295	1900

For the mounting manual of this scraper please visit our web site:  
[www.rulmeca.com](http://www.rulmeca.com) / Bulk products / accessories / scrapers



**Pre-Scraper  
with separated flexible PU blades  
Type PU 91**

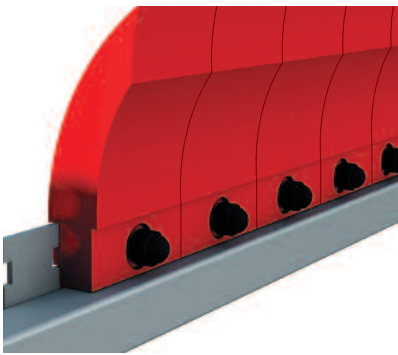
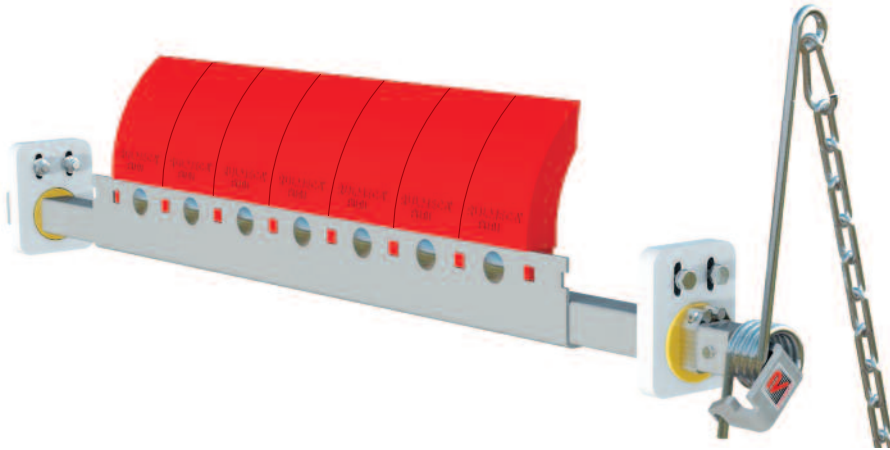

The PU91 pre-scraper with scraper segments that flex individually. It is fitted at the front of the drive pulley, with the pu-blades just below the horizontal centre line of the pulley, at right angles to the conveyor belt. Can be fitted with tungsten-carbide blades.

B-W 400-2000mm

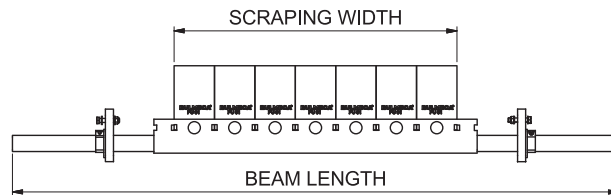
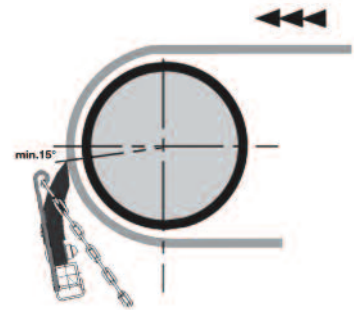

Belt Width	Segments	Scraping Width	Beam Length
400	4	350	1150
500	5	450	1250
650	6	550	1350
800	7	700	1500
1000	9	900	1700
1200	11	1050	1850
1400	13	1250	2050
1600	15	1450	2250
1800	17	1650	2450
2000	19	1850	2650

For the mounting manual of this scraper please visit our web site:  
[www.rulmeca.com](http://www.rulmeca.com) / Bulk products / accessories / scrapers



# Secondary Scraper with single PU blade Type PU 92

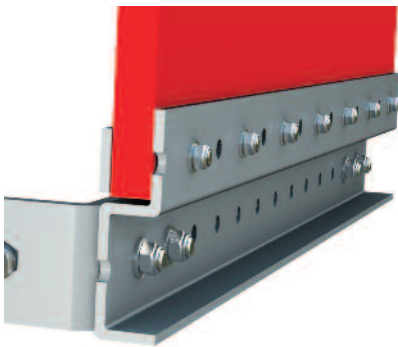
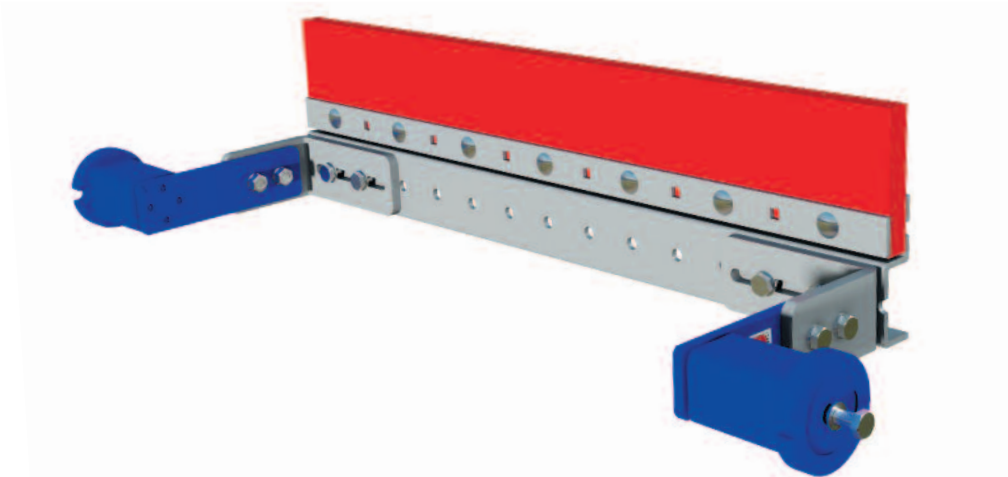

PU 92 secondary scraper is placed below the drive pulley. The pressure of the PU strip against the belt is produced by two pre tensioned torsion springs. The installation dimensions of the scraper can be continuously adjusted. The scraper cannot be used on belts with reversible operations. Can be fitted with tungsten-carbide blades.

BW 400-2000

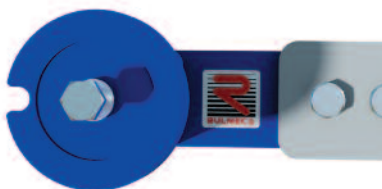
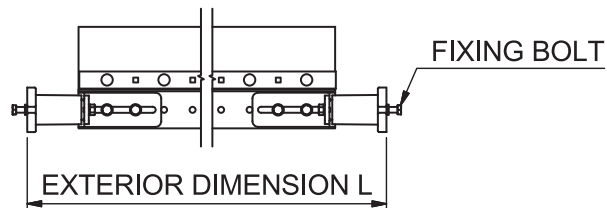
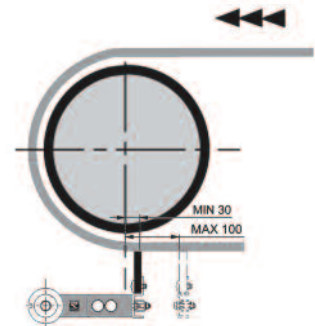

Belt Width	Scraping Width	L - Length
400	400	482 - 582
500	500	582 - 682
650	600	582 - 682
800	700	840 - 940
1000	900	1040 - 1140
1200	1100	1240 - 1340
1400	1200	1440 - 1540
1600	1400	1700 - 1800
1800	1600	1900 - 2000
2000	1800	2100 - 2200

For the mounting manual of this scraper please visit our web site:  
[www.rulmeca.com](http://www.rulmeca.com) / Bulk products / accessories / scrapers





# Plough Scraper with a couple of PU blades Type PU 88

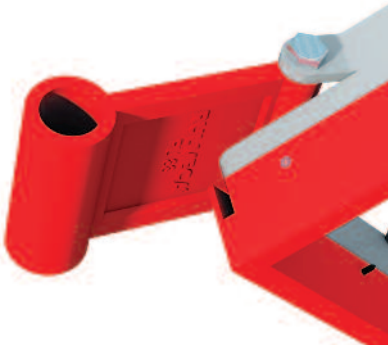
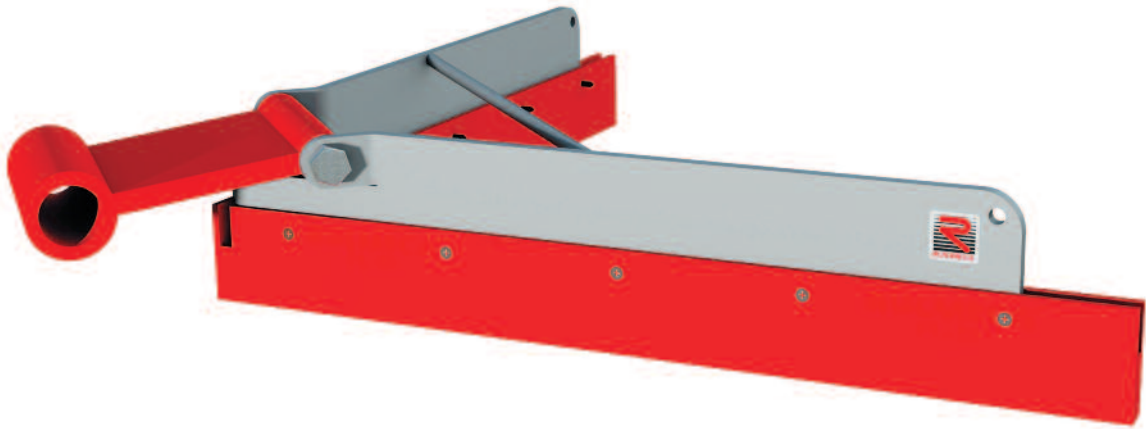

The PU 88 is a stable plough with steel frame and exchangeable pu-scraper strips. When fitting the plough, a tube of diameter 40 mm is threaded through the PU link. The tube is then fixed to the frame of the conveyor. The plough can be modified for reversible drive.

B-W 400-1800mm

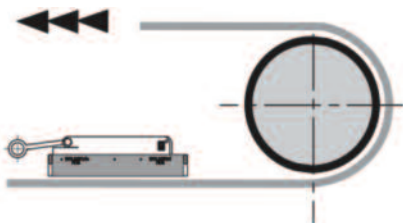
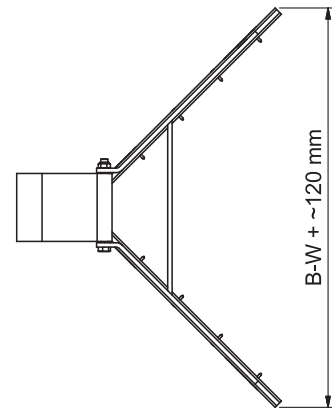
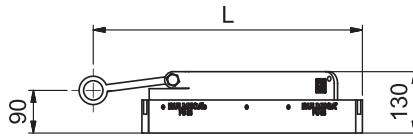

Belt Width	L
400	380
500	430
650	510
800	570
1000	680
1200	780
1400	880
1600	980
1800	1080

For the mounting manual of this scraper please visit our web site:  
[www.rulmeca.com](http://www.rulmeca.com) / Bulk products / accessories / scrapers





**CODES**  
PU Series - Polyurethane Scrapers



**Type PU-83**  
Simple Pre-scraper with single polyurethane blade

Article Code	Description
PU_83_400	Scraper PU-83 BW 400 SW = 350 single tensioning lever arm
PU_83_500	Scraper PU-83 BW 500 SW = 450 single tensioning lever arm
PU_83_650	Scraper PU-83 BW 650 SW = 550 single tensioning lever arm
PU_83_800	Scraper PU-83 BW 800 SW = 700 single tensioning lever arm
PU_83_1000	Scraper PU-83 BW 1000 SW = 900 double tensioning lever arm
PU_83_1200	Scraper PU-83 BW 1200 SW = 1050 double tensioning lever arm
PU_83_1400	Scraper PU-83 BW 1400 SW = 1250 double tensioning lever arm
PU_83_1600	Scraper PU-83 BW 1600 SW = 1450 double tensioning lever arm
PU_83_1800	Scraper PU-83 BW 1800 SW = 1650 double tensioning lever arm
PU_83_2000	Scraper PU-83 BW 2000 SW = 1850 double tensioning lever arm

**Type PU-89**  
Heavy Pre- scraper with single polyurethane blade

PU_89_650	Scraper PU-89 BW 650 SW = 545
PU_89_800	Scraper PU-89 BW 800 SW = 695
PU_89_1000	Scraper PU-89 BW 1000 SW = 895
PU_89_1200	Scraper PU-89 BW 1200 SW = 1095
PU_89_1400	Scraper PU-89 BW 1400 SW = 1295

**Type PU-91**  
Pre- scraper with segmented polyurethane blades

PU_91_400	Scraper PU-91 BW 400 SW = 400 single tensioning lever arm
PU_91_500	Scraper PU-91 BW 500 SW = 500 single tensioning lever arm
PU_91_650	Scraper PU-91 BW 650 SW = 600 single tensioning lever arm
PU_91_800	Scraper PU-91 BW 800 SW = 700 single tensioning lever arm
PU_91_1000	Scraper PU-91 BW 1000 SW = 900 double tensioning lever arm
PU_91_1200	Scraper PU-91 BW 1200 SW = 1100 double tensioning lever arm
PU_91_1400	Scraper PU-91 BW 1400 SW = 1300 double tensioning lever arm
PU_91_1600	Scraper PU-91 BW 1600 SW = 1500 double tensioning lever arm
PU_91_1800	Scraper PU-91 BW 1800 SW = 1700 double tensioning lever arm
PU_91_2000	Scraper PU-91 BW 2000 SW = 1900 double tensioning lever arm
PU_91_2200	Scraper PU-91 BW 2200 SW = 2100 double tensioning lever arm
PU_91_2400	Scraper PU-91 BW 2400 SW = 2300 double tensioning lever arm

**Type PU-92**  
Secondary scraper with single polyurethane blade

PU_92_400	Secondary scraper PU-92 BW 400 SW = 400
PU_92_500	Secondary scraper PU-92 BW 500 SW = 500
PU_92_650	Secondary scraper PU-92 BW 650 SW = 600
PU_92_800	Secondary scraper PU-92 BW 800 SW = 700
PU_92_1000	Secondary scraper PU-92 BW 1000 SW = 900
PU_92_1200	Secondary scraper PU-92 BW 1200 SW = 1100
PU_92_1400	Secondary scraper PU-92 BW 1400 SW = 1300
PU_92_1600	Secondary scraper PU-92 BW 1600 SW = 1500

**Type PU-88**  
Plough scraper - V form PU blades

PU_88_400	Plough scraper PU-88 BW 400
PU_88_500	Plough scraper PU-88 BW 500
PU_88_650	Plough scraper PU-88 BW 650
PU_88_800	Plough scraper PU-88 BW 800
PU_88_1000	Plough scraper PU-88 BW 1000
PU_88_1200	Plough scraper PU-88 BW 1200
PU_88_1400	Plough scraper PU-88 BW 1400
PU_88_1600	Plough scraper PU-88 BW 1600



## CODES

SPU Spare Parts & Accessories - PU Series Scrapers



# SCHIKI

**Ref. PU-83**  
Simple Pre-scraper with  
single polyurethane blade

Article Code	Description
<b>SPU_8324</b>	Polyurethane blades SPU 8324 SW = 350 for scrapers PU 83 BW 400
<b>SPU_8325</b>	Polyurethane blades SPU 8325 SW = 450 for scrapers PU 83 BW 500
<b>SPU_8326</b>	Polyurethane blades SPU 8326 SW = 550 for scrapers PU 83 BW 650
<b>SPU_8328</b>	Polyurethane blades SPU 8328 SW = 700 for scrapers PU 83 BW 800
<b>SPU_8330</b>	Polyurethane blades SPU 8330 SW = 900 for scrapers PU 83 BW 1000
<b>SPU_8332</b>	Polyurethane blades SPU 8332 SW = 1050 for scrapers PU 83 BW 1200
<b>SPU_8334</b>	Polyurethane blades SPU 8334 SW = 1250 for scrapers PU 83 BW 1400
<b>SPU_8336</b>	Polyurethane blades SPU 8336 SW = 1450 for scrapers PU 83 BW 1600
<b>SPU_8338</b>	Polyurethane blades SPU 8338 SW = 1650 for scrapers PU 83 BW 1800
<b>SPU_8340</b>	Polyurethane blades SPU 8340 SW = 1850 for scrapers PU 83 BW 2000

**Ref. PU-89**  
Heavy Pre- scraper with  
single polyurethane blade

<b>SPU_8926</b>	Polyurethane blades SPU 8926 SW = 545 for scrapers PU 89 BW 650
<b>SPU_8928</b>	Polyurethane blades SPU 8928 SW = 695 for scrapers PU 89 BW 800
<b>SPU_8930</b>	Polyurethane blades SPU 8930 SW = 895 for scrapers PU 89 BW 1000
<b>SPU_8932</b>	Polyurethane blades SPU 8932 SW = 1095 for scrapers PU 89 BW 1200
<b>SPU_8934</b>	Polyurethane blades SPU 8934 SW = 1295 for scrapers PU 89 BW 1400

**Ref. PU-91**  
Pre- scraper with segment-  
ed polyurethane blades

<b>SPU_9100</b>	Blade sections in Polyurethane SPU 9100 for scrapers PU 91
-----------------	--

**Ref. PU-92**  
Secondary scraper with  
single polyurethane blade

<b>SPU_9224</b>	Polyurethane blades SPU 9224 SW = 400 for scrapers PU 92 BW 400
<b>SPU_9225</b>	Polyurethane blades SPU 9225 SW = 500 for scrapers PU 92 BW 500
<b>SPU_9226</b>	Polyurethane blades SPU 9226 SW = 600 for scrapers PU 92 BW 650
<b>SPU_9228</b>	Polyurethane blades SPU 9228 SW = 700 for scrapers PU 92 BW 800
<b>SPU_9230</b>	Polyurethane blades SPU 9230 SW = 900 for scrapers PU 92 BW 1000
<b>SPU_9232</b>	Polyurethane blades SPU 9232 SW = 1100 for scrapers PU 92 BW 1200
<b>SPU_9234</b>	Polyurethane blades SPU 9234 SW = 1300 for scrapers PU 92 BW 1400
<b>SPU_9236</b>	Polyurethane blades SPU 9236 SW = 1500 for scrapers PU 92 BW 1600
<b>SPU_9238</b>	Polyurethane blades SPU 9238 SW = 1700 for scrapers PU 92 BW 1800
<b>SPU_9240</b>	Polyurethane blades SPU 9240 SW = 1900 for scrapers PU 92 BW 2000

**Ref. PU-88**  
Plough scraper sets of PU V  
blades

<b>SPU_8824</b>	Set of Polyurethane blades SPU 8824 L1 = 350 L2 = 370 for plough scrapers PU 88 BW 400
<b>SPU_8825</b>	Set of Polyurethane blades SPU 8825 L1 = 420 L2 = 440 for plough scrapers PU 88 BW 500
<b>SPU_8826</b>	Set of Polyurethane blades SPU 8826 L1 = 540 L2 = 560 for plough scrapers PU 88 BW 650
<b>SPU_8828</b>	Set of Polyurethane blades SPU 8828 L1 = 630 L2 = 650 for plough scrapers PU 88 BW 800
<b>SPU_8830</b>	Set of Polyurethane blades SPU 8830 L1 = 780 L2 = 800 for plough scrapers PU 88 BW 1000
<b>SPU_8832</b>	Set of Polyurethane blades SPU 8832 L1 = 920 L2 = 940 for plough scrapers PU 88 BW 1200
<b>SPU_8834</b>	Set of Polyurethane blades SPU 8834 L1 = 1060 L2 = 1080 for plough scrapers PU 88 BW 1400
<b>SPU_8836</b>	Set of Polyurethane blades SPU 8836 L1 = 1230 L2 = 1250 for plough scrapers PU 88 BW 1600

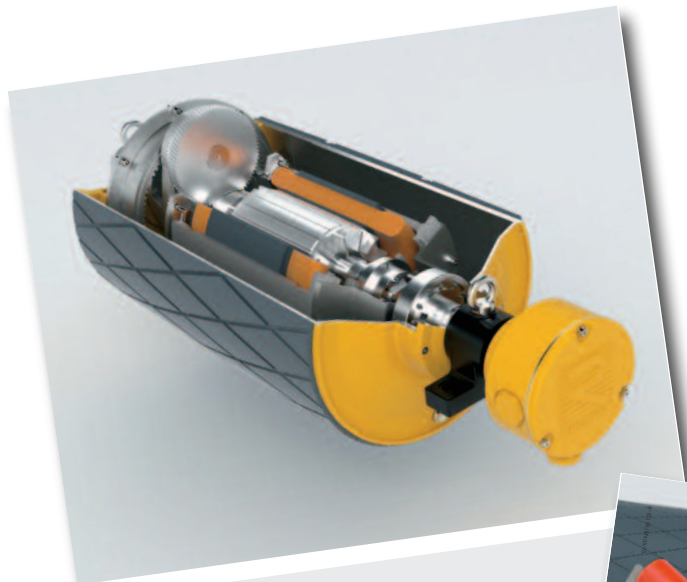

MOTORIZED PULLEYS  
FOR BELT CONVEYORS  
BULK HANDLING  
GENERAL CATALOGUE

**Moving ahead.**

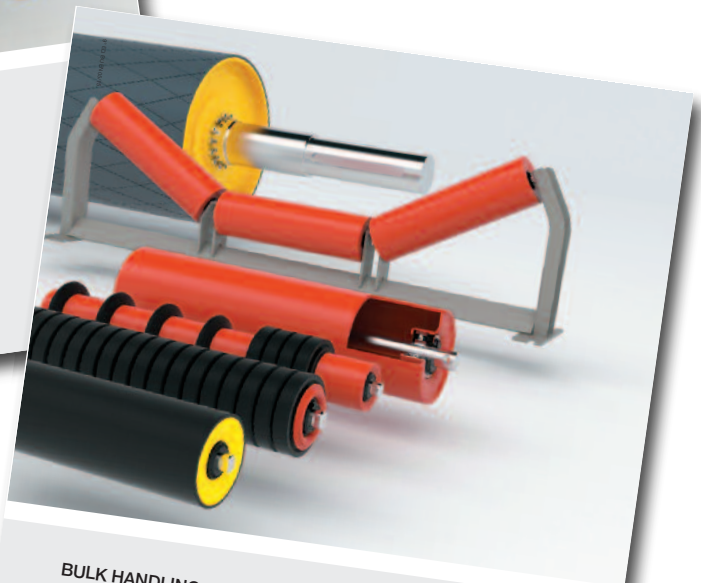

BULK HANDLING  
ROLLERS AND COMPONENTS  
FOR BULK HANDLING

**Moving ahead.**



For full details about our range of products, please request our separate master catalogues:

- Rollers and components for bulk handling
- Motorized Pulleys for belt conveyors

or visit our web site [www.rulmeca.com](http://www.rulmeca.com)

**Rulmeca Holding S.p.A.**

Via A. Toscanini, 1  
I-24011 Almè (BG) Italy  
Tel. +39 035 4300111  
Fax +39 035 545700  
export-it@rulmeca.com  
[www.rulmeca.com](http://www.rulmeca.com)



**SCHIKI**

